

## Challenger Hot Food Trolleys



Corsair Challenger HMP Trolleys are designed for the safe, easy and efficient transportation of hot food from central/main kitchen areas to wing serveries and other remote serving points.

Based on over 3 decades of experience of successful service in the Custodial Estate throughout the UK, the Challenger Range comes with a 24-month warranty and features:

- Strong, sturdy and easy to manoeuvre castors
- Push/Pull handle on both ends
- Protective 360° bumper-rail - strong and shock-absorbent
- Easy to remove G/N housing Frame for 10 off 1/1 containers
- Ease of emptying, refilling and cleaning - 180 deg opening doors
- Gallery Rail for the retention of articles on top
- Effective and easy to operate, cable-free Dead Man's Break
- Proven heating and insulating performance
- Easy to use plug storage point
- 13A power supply - commando connector if required



**Corsair**

*A Proud British Manufacturer of Commercial Catering Equipment*

CORSAIR ENGINEERING LTD., BEAUMONT CLOSE,  
BEAUMONT INDUSTRIAL ESTATE, BANBURY, OXON. OX16 1SH  
Telephone: 0044 (0)1295 267021 Fax: 0044 (0)1295 270396  
E-mail: [info@corsairengineering.co.uk](mailto:info@corsairengineering.co.uk)  
[www.corsairengineering.co.uk](http://www.corsairengineering.co.uk)



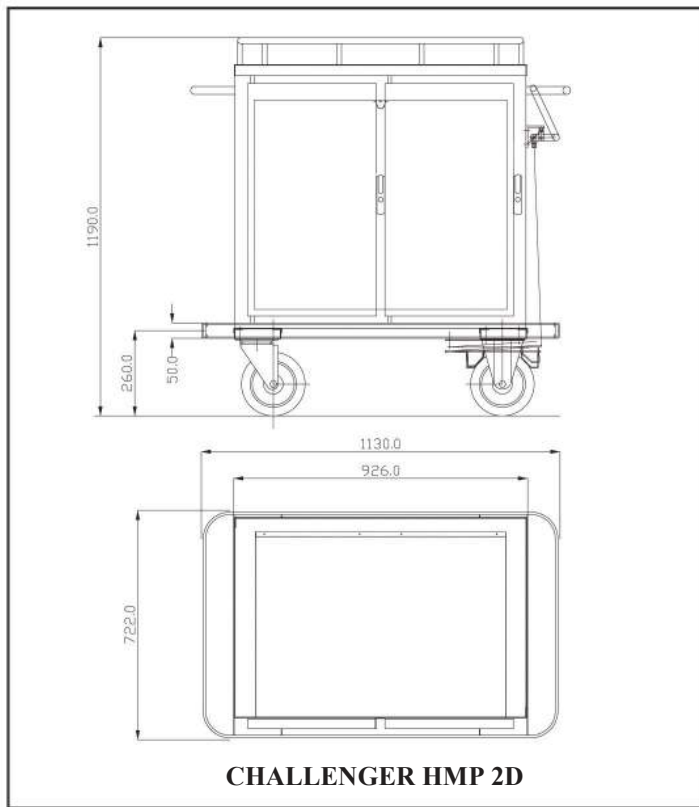

**CHALLENGER HMP 2D**

### Specification

- External dimensions - 1130mm long x 722mm wide x 1190mm high
- Internal dimensions - 795mm long x 550mm wide x 700mm high
- Weight (unladen) - 160kg approx
- Electrical loading - 1.5kw single phase
- Capacity - each rack holding 10 x 1/1 G/N containers 40mm deep per section
- Racks removable for cleaning
- Castors - 2 fixed & 2 swivel standard 200mm dia non-marking
- Single heated compartment with access through 2 doors
- Tamper proof digital temperature display set at 85° C
- Door seals - solid silicon rubber - easily replaceable
- Excellent heat retention
- Radiused corners to compartment for ease of cleaning
- Heavy duty chassis with non-marking bumper rail

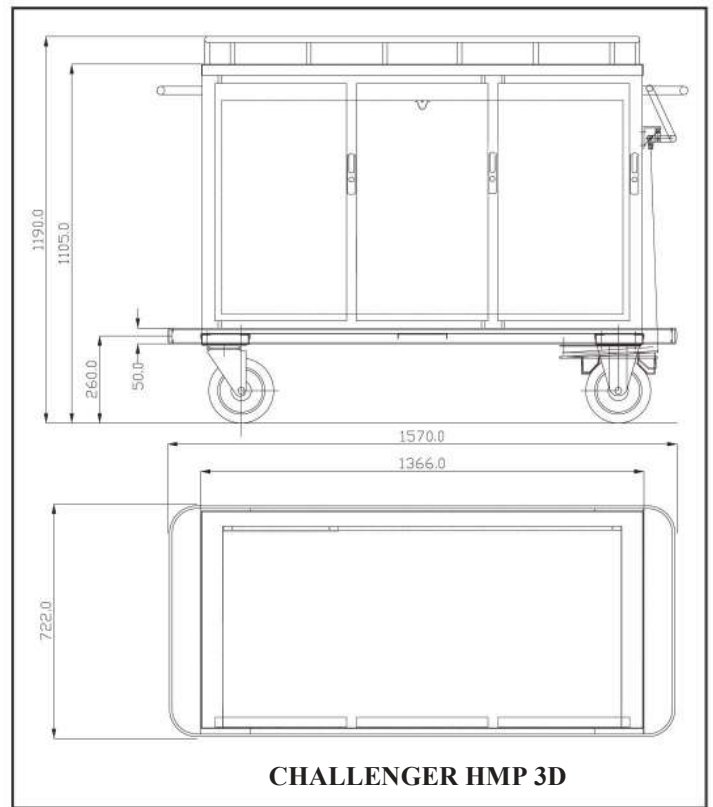

**CHALLENGER HMP 3D**

### Specification

- External dimensions - 1570mm long x 722mm wide x 1190mm high
- Internal dimensions - 1235mm long x 550mm wide x 700mm high
- Weight (unladen) - 190kg approx
- Electrical loading - 1.5kw single phase
- Capacity - each rack holding 10 x 1/1 G/N containers 40mm deep per section
- Racks removable for cleaning
- Castors - 2 fixed & 2 swivel standard 200mm dia non-marking
- Single heated compartment with access through 3 doors
- Tamper proof digital temperature display set at 85° C
- Door seals - solid silicon rubber - easily replaceable
- Excellent heat retention
- Radiused corners to compartment for ease of cleaning
- Heavy duty chassis with non-marking bumper rail

### Optional Extras

- Tow bar to facilitate mechanical towing of trolleys
- Higher capacity trolleys (taller) for larger HMP establishments
- Rough terrain castors
- Individual compartments with independent controls
- Eutectic Plate option for chilled food service